

PRUA LIFT

ISTRUZIONI DI MONTAGGIO ASSEMBLY INSTRUCTIONS

MODELLI
MODELS:

411/78.1186.22
411/78.1187.22

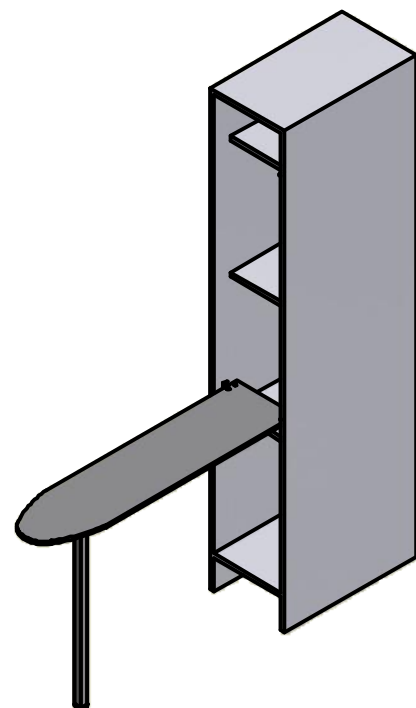

CONTENUTO DELLA CONFEZIONE INCLUDED IN THE PACKAGING

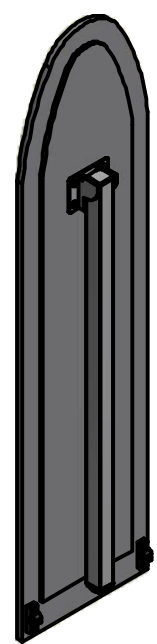

PIANO+GAMBA
TOP+LEG

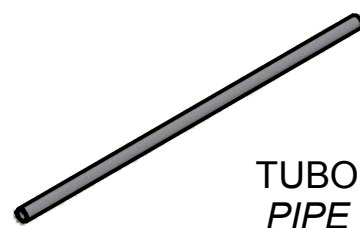

TUBO
PIPE

SACCHETTO ACCESSORI - ACCESSORIES

- A. Chiave esa. 3 - n° 3 Allen key (x 1)
- B. Bussola M5 - M5 bush (x 4)
- C. Vite TPS M5x16 - M6x16 FHCS screw (x 4)
- D. Vite truciolare 4x16 - 4x16 FHP screw (x1)
- E. Tubo - Pipe (x2)
- F. Distanziale - Spacer (x2)
- G. Leva - Lever (x 1)

DIMENSIONI GENERALI MOBILE GENERAL CABINET DIMENSIONS

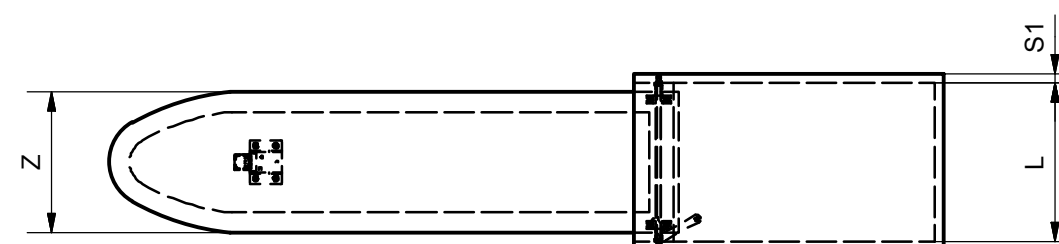
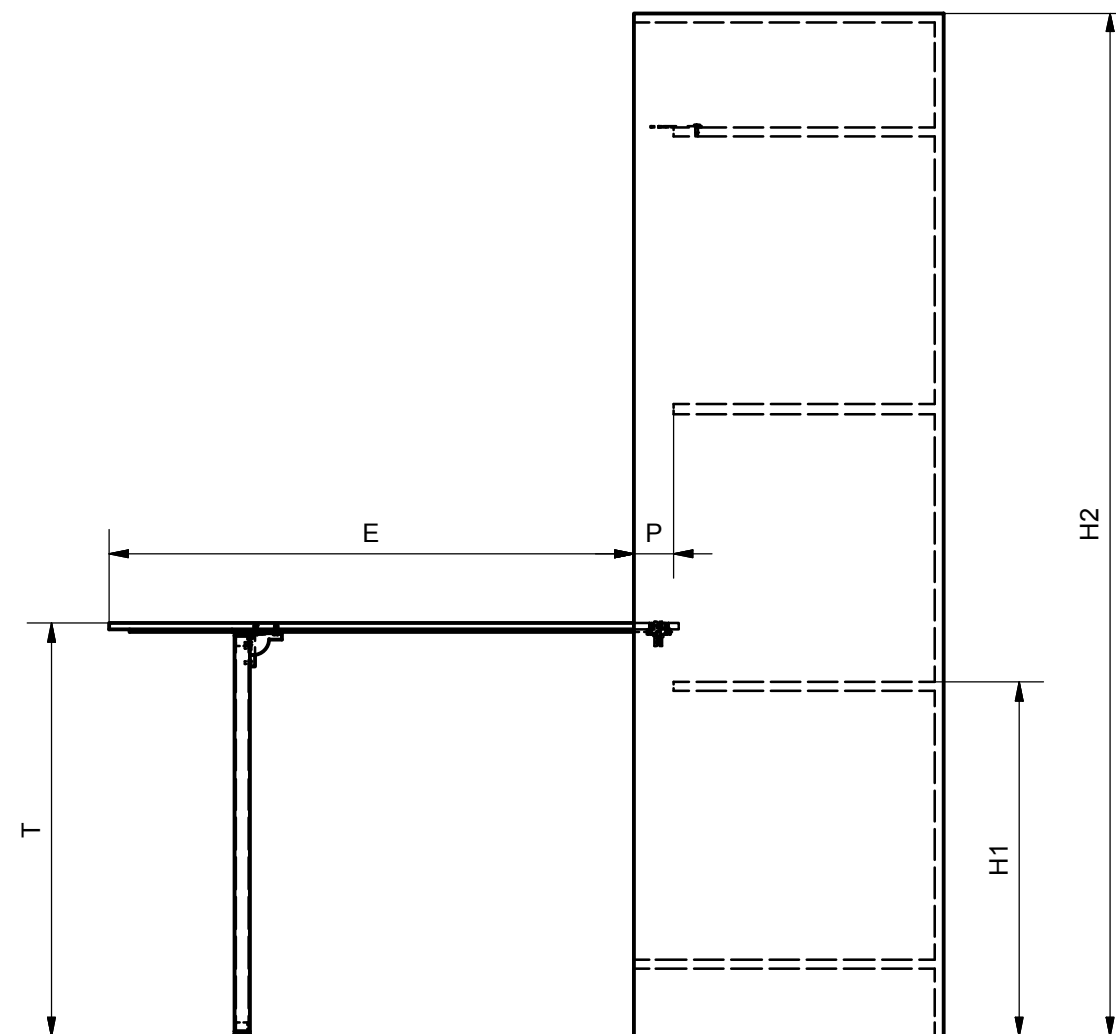

DIMENSIONE - DIMENSION	SIMBOLO - SYMBOL	mm
ALTEZZA PIANO CABINET - TOP CABINET HEIGHT	H1	MIN: 150
ALTEZZA CABINET - CABINET HEIGHT	H2	MIN: 2000
PROFONDITA' - DEPTH	P	MIN: 80
LARGHEZZA - WIDTH	L1	MIN: 310 MAX: 420
SPESSORI SPALLE - SIDE THICKNESS	S1	15-20 mm
LARGHEZZA PIANO - TOP WIDTH	Z	280/380
APERTURA PIANO - TOP OPENING	E	1050
ALTEZZA MECCANISMO - MECHANISM HEIGHT	T	820

MONTAGGIO DEL MECCANISMO MOUNTING OF THE MECHANISM

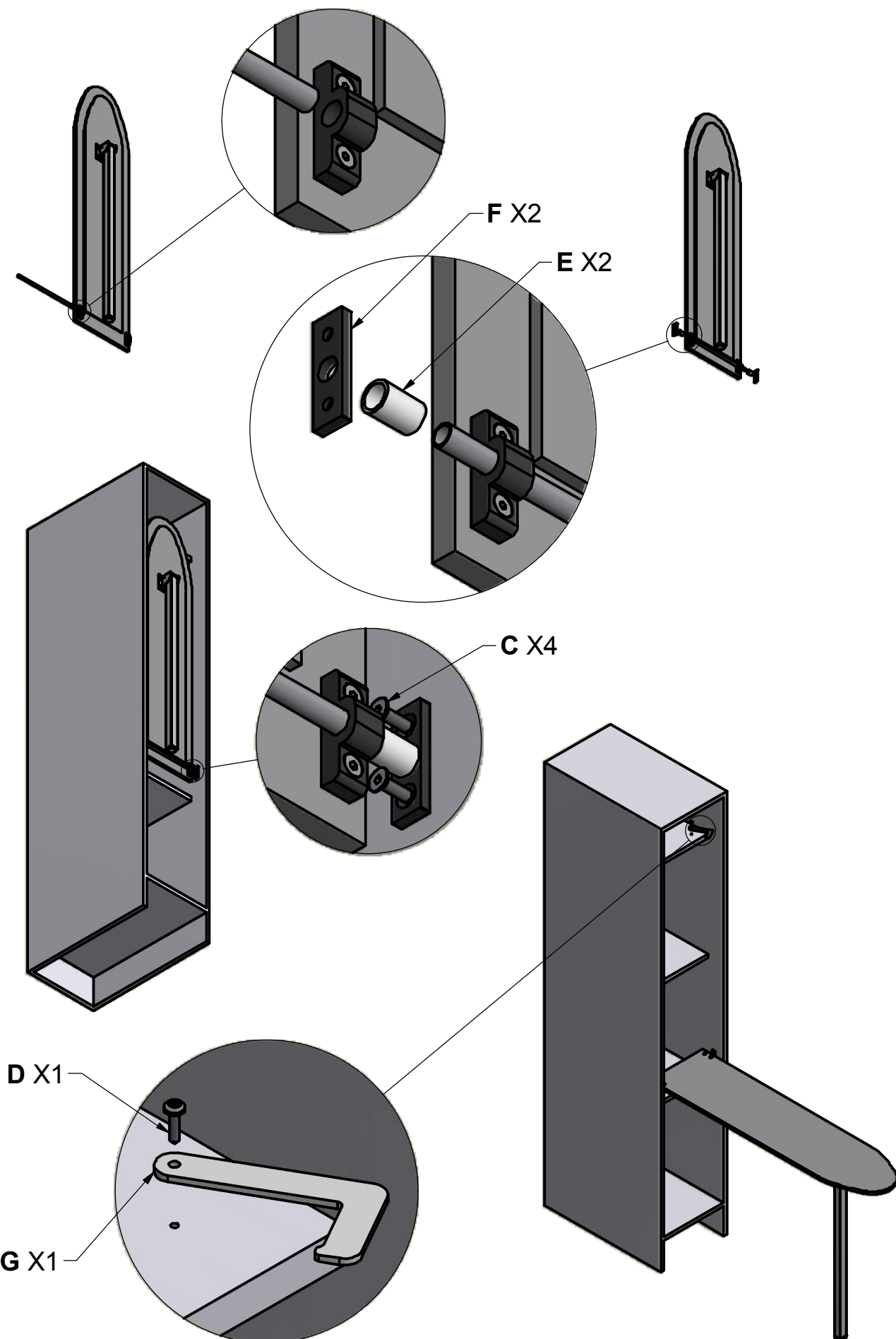

POSIZIONE FORI FISSAGGIO POSITION FIXING HOLES

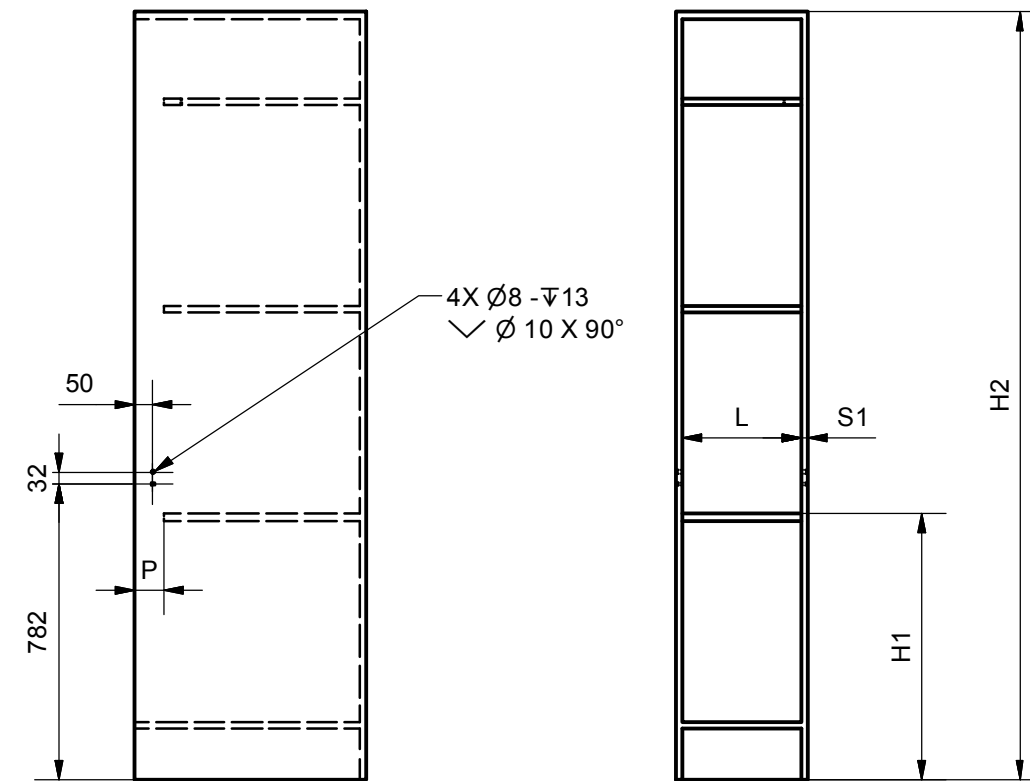

SEQUENZA DI FUNZIONAMENTO FUNCTIONING STEPS

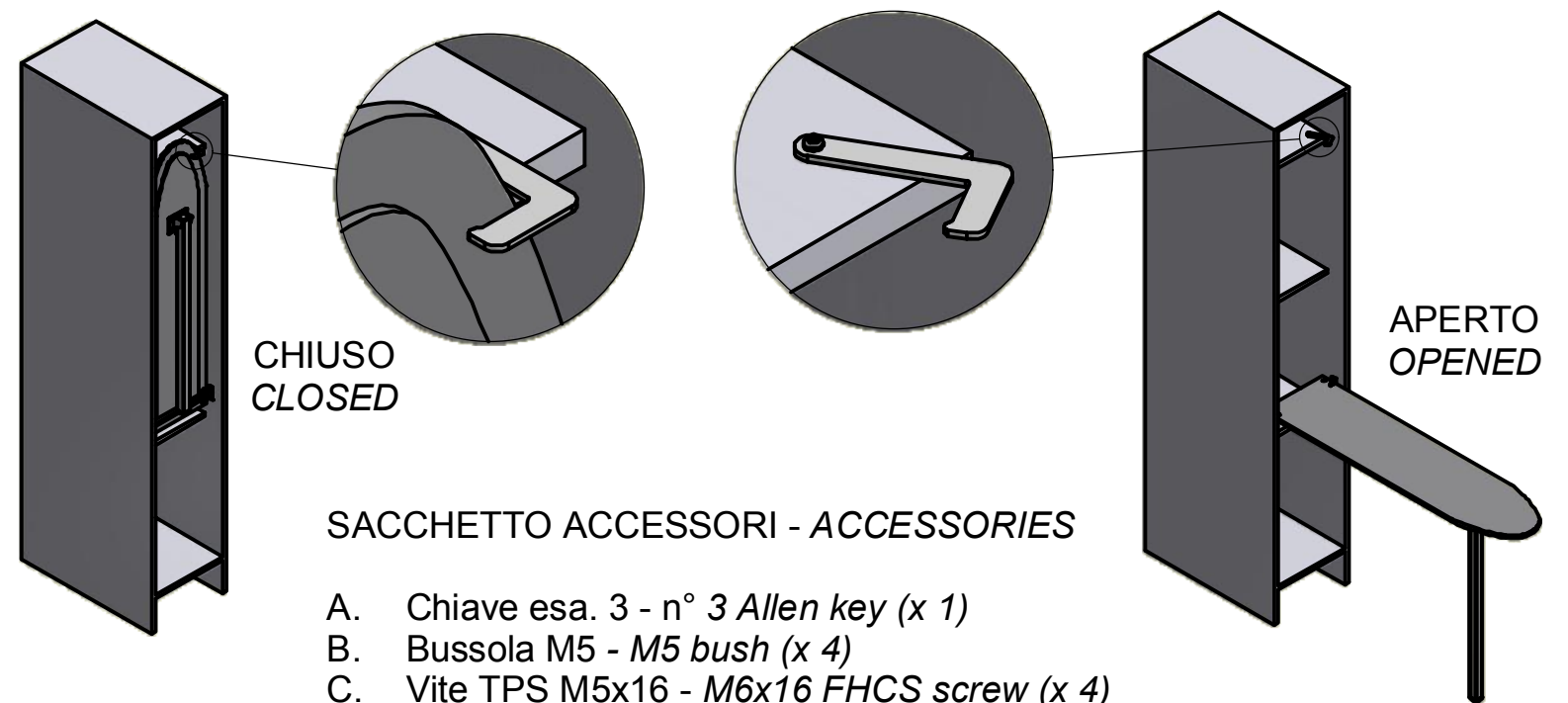

- SACCHETTO ACCESSORI - ACCESSORIES
- A. Chiave esa. 3 - n° 3 Allen key (x 1)
 - B. Bussola M5 - M5 bush (x 4)
 - C. Vite TPS M5x16 - M6x16 FHCS screw (x 4)
 - D. Vite truciolare 4x16 - 4x16 FHP screw (x1)
 - E. Tubo - Pipe (x2)
 - F. Distanziale - Spacer (x2)
 - G. Leva - Lever (x 1)