

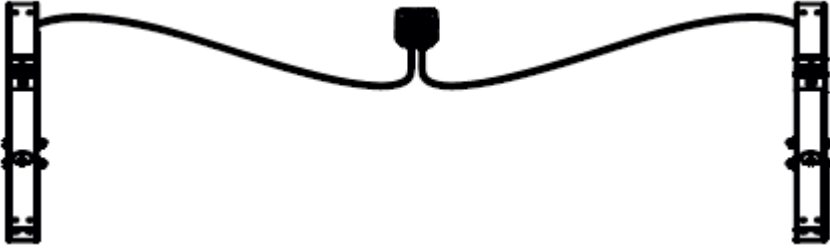







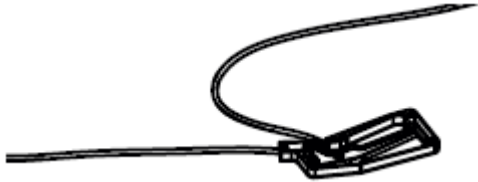

	<p><b>Column Lift with Roller Guide</b></p> <p>2 pcs.</p>
	<p><b>1400/1600/1800/2000 Crossbar</b></p> <p>1 pc.</p>
	<p><b>Crossbar</b></p> <p>1 pc.</p>
	<p><b>Foot Crossbar</b></p> <p>1 pc.</p>
	<p><b>Foot Tube Symmetrical</b></p>
	<p><b>Foot Tube Asymmetrical</b></p> <p>2 pcs.</p>
	<p><b>Right and Left Brackets</b></p> <p>1 pc. of each</p>
	<p><b>Hand Release</b></p> <p>1 pc.</p>

	<p><b>Castor</b></p> <p><b>2 pcs.</b></p>
	<p><b>Castor with Wheel Brake</b></p> <p><b>2 pcs.</b></p>
	<p><b>Threaded Bolt</b></p> <p><b>4 pcs.</b></p>
	<p><b>Cylinder Screw with Hexagon Socket M8 x 80mm</b></p> <p><b>4 pcs.</b></p>
	<p><b>Cylinder Screw with Hexagon Socket M8 x 20mm</b></p> <p><b>12 pcs.</b></p>
	<p><b>Mounting Clip</b></p> <p><b>4 pcs.</b></p>
	<p><b>Button-Head Screw Ø5 x 25mm</b></p> <p><b>8 pcs.</b></p>
	<p><b>Button-Head Screw Ø4 x 16mm</b></p> <p><b>10 pcs.</b></p>

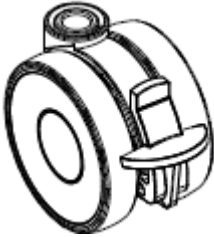
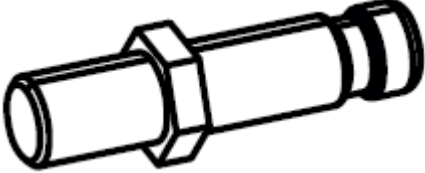

**BOX 15**

- INTERIOR UPSCALING -

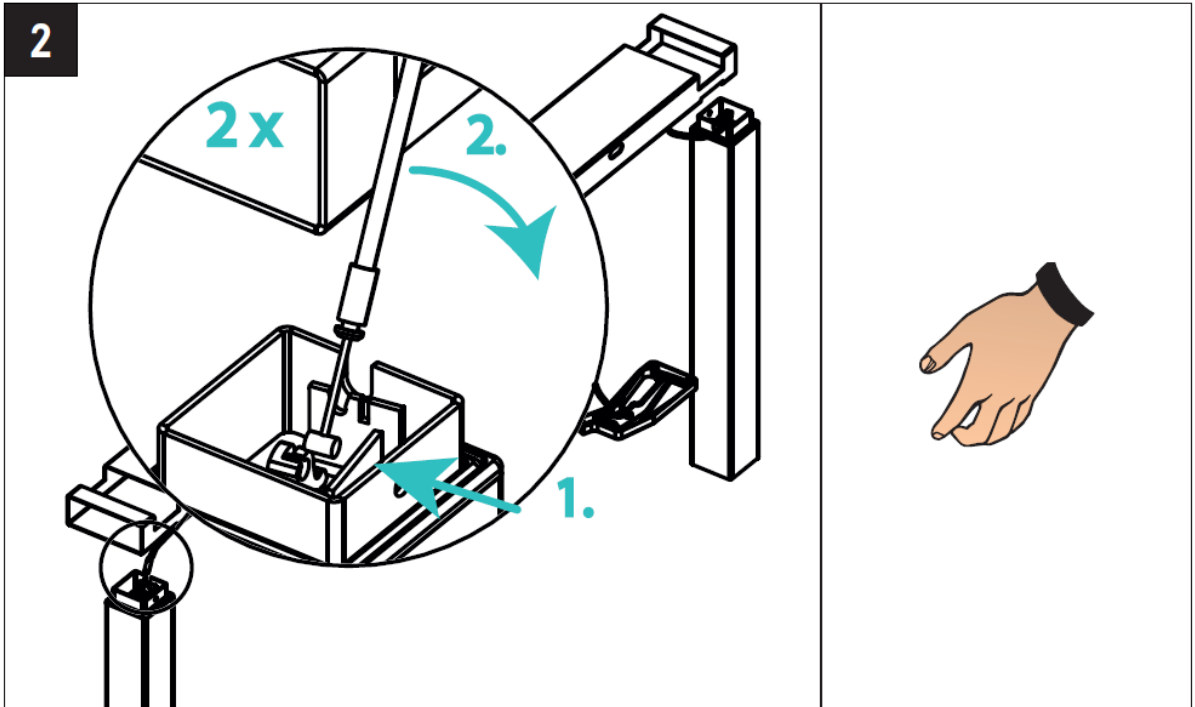
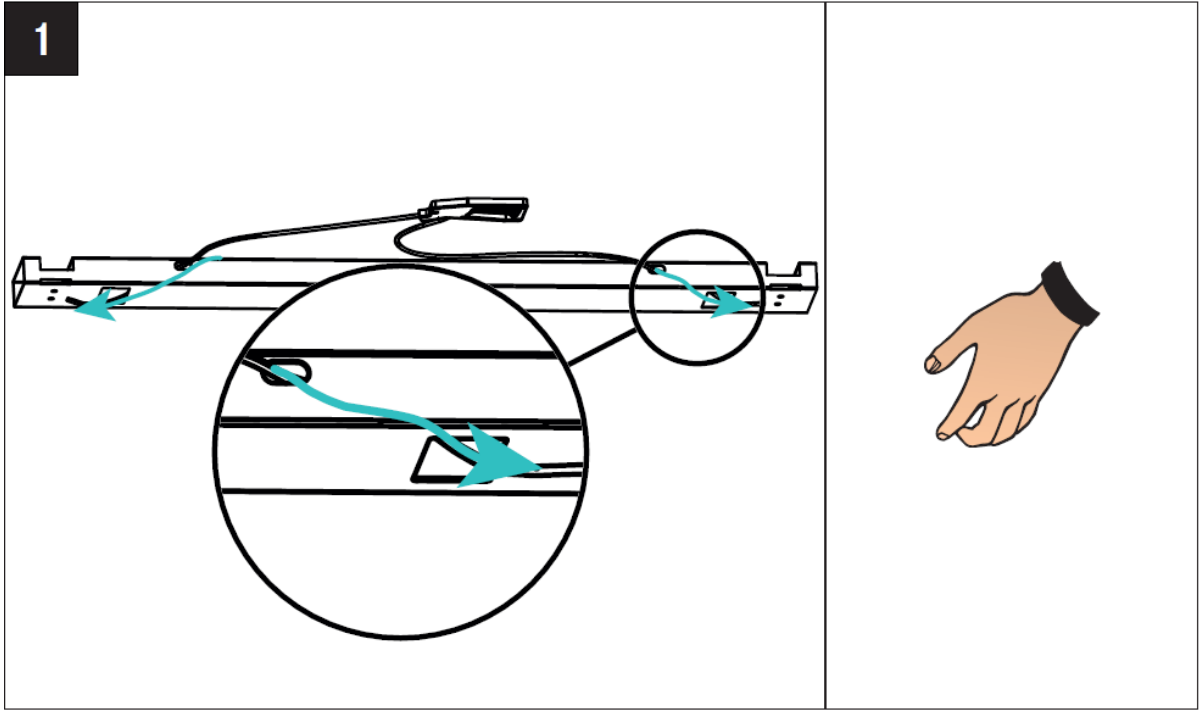
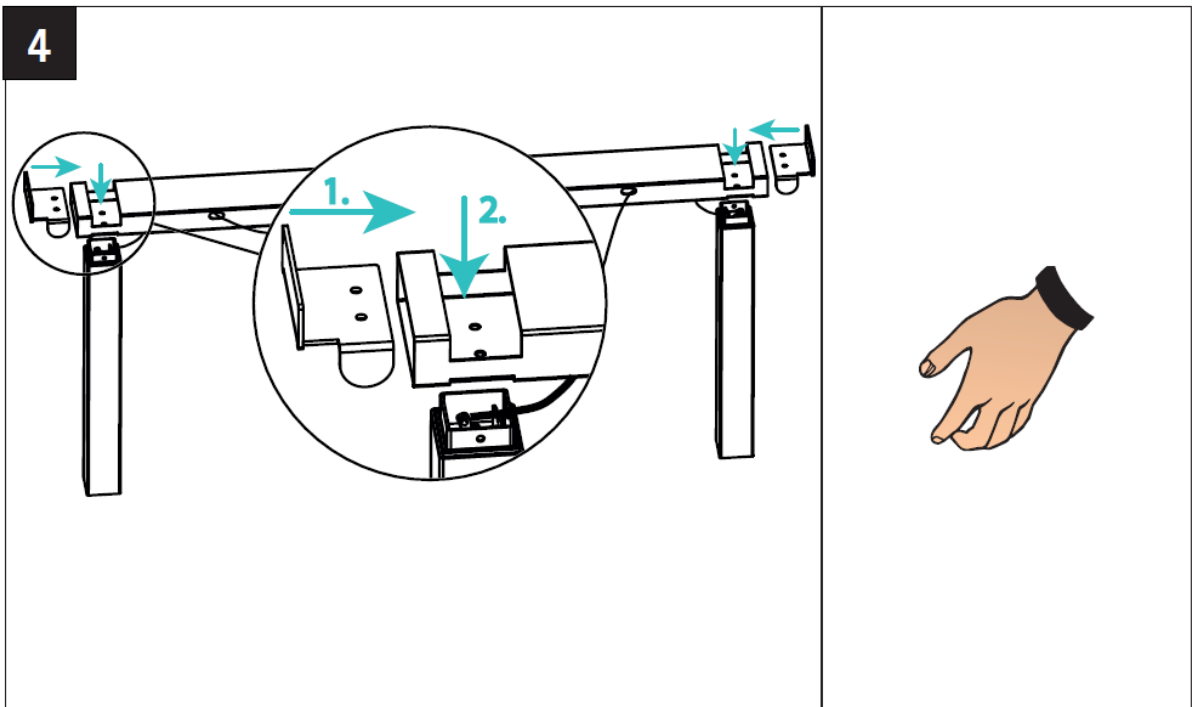
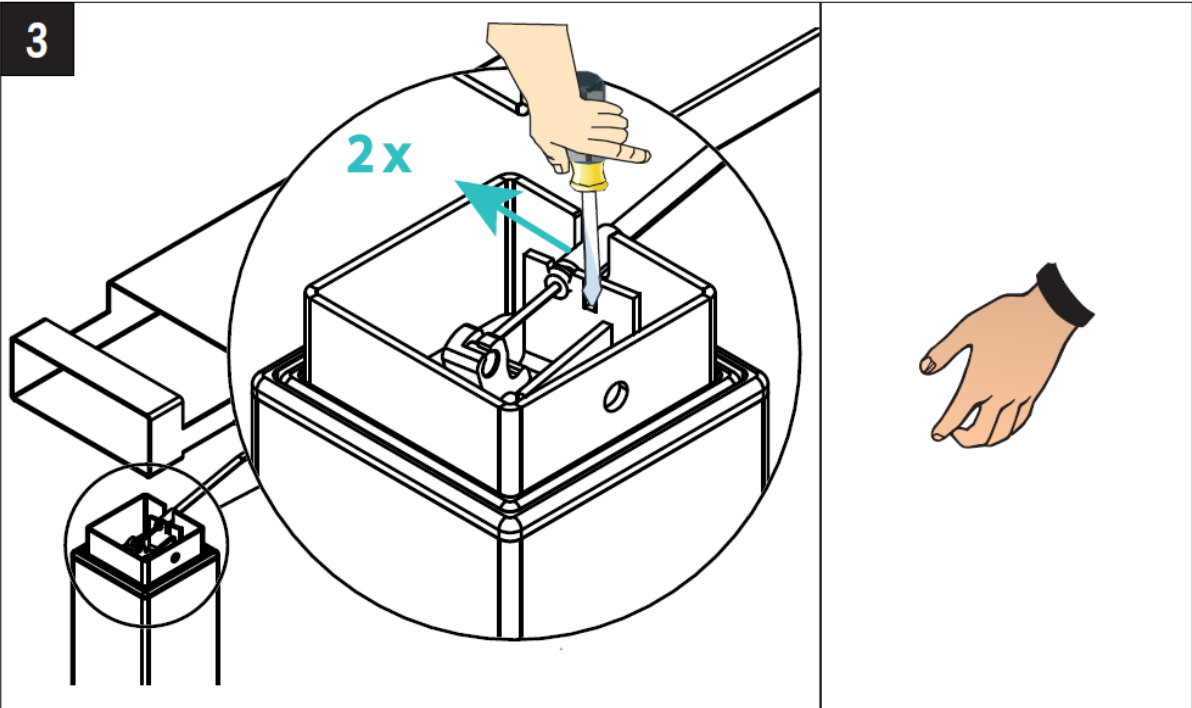

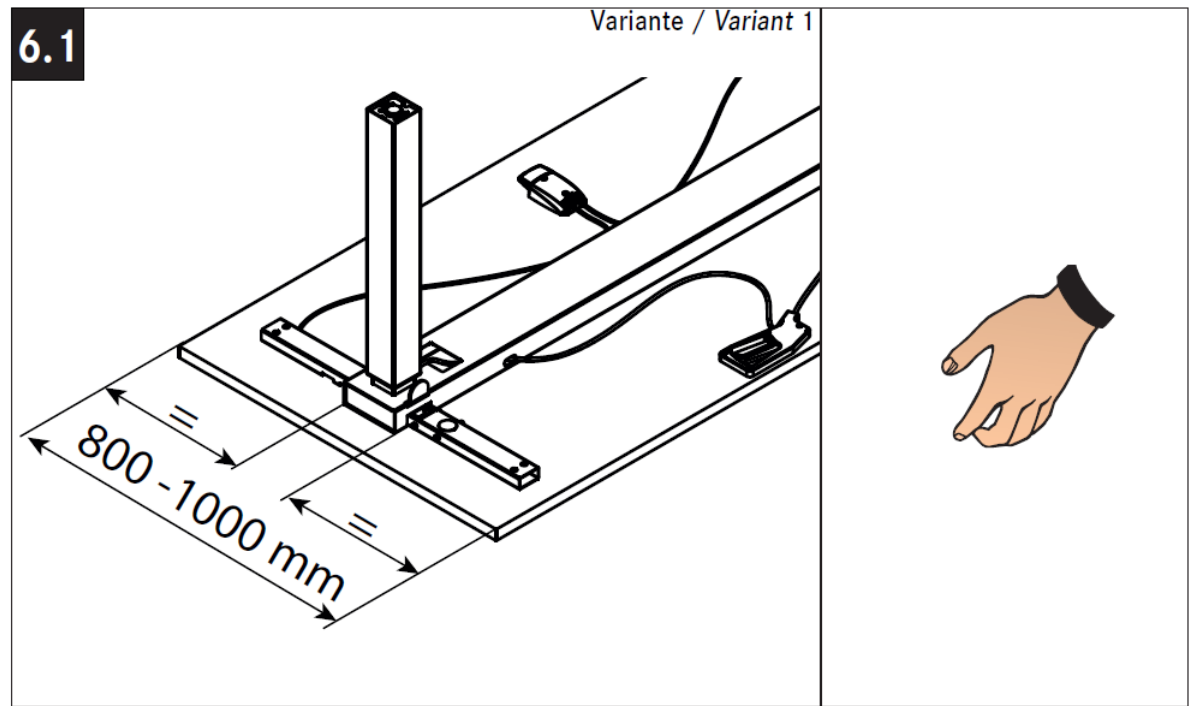
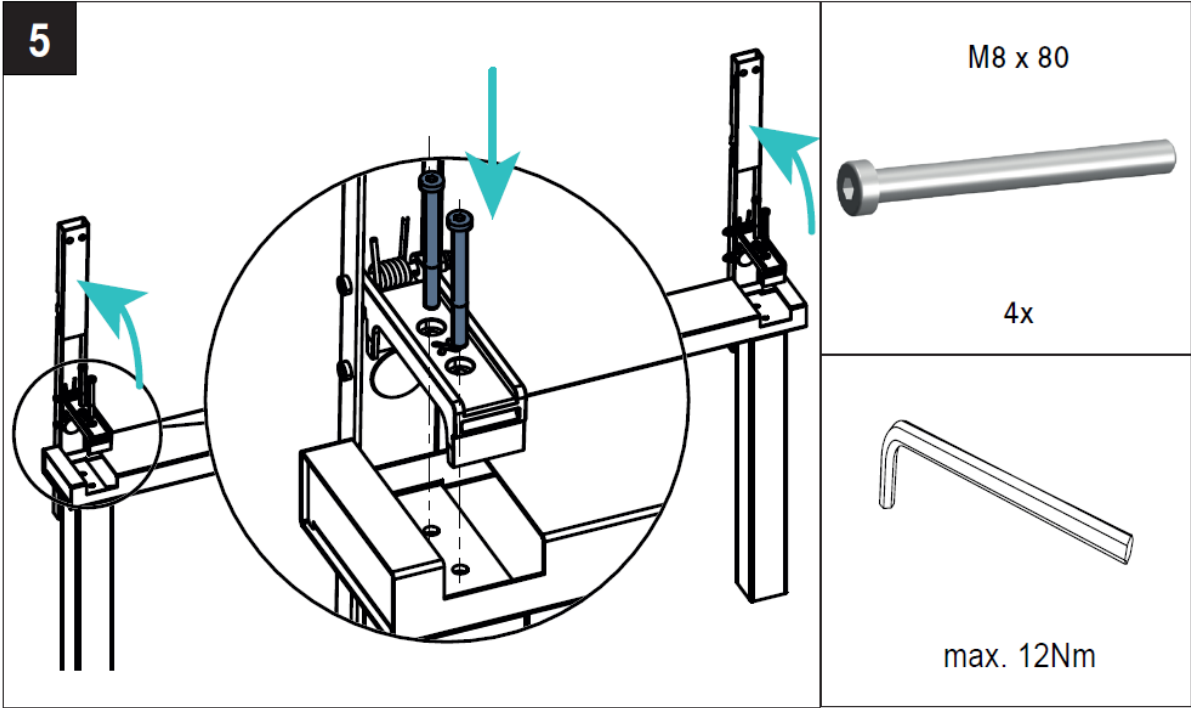

6.2

Variante / Variant 2

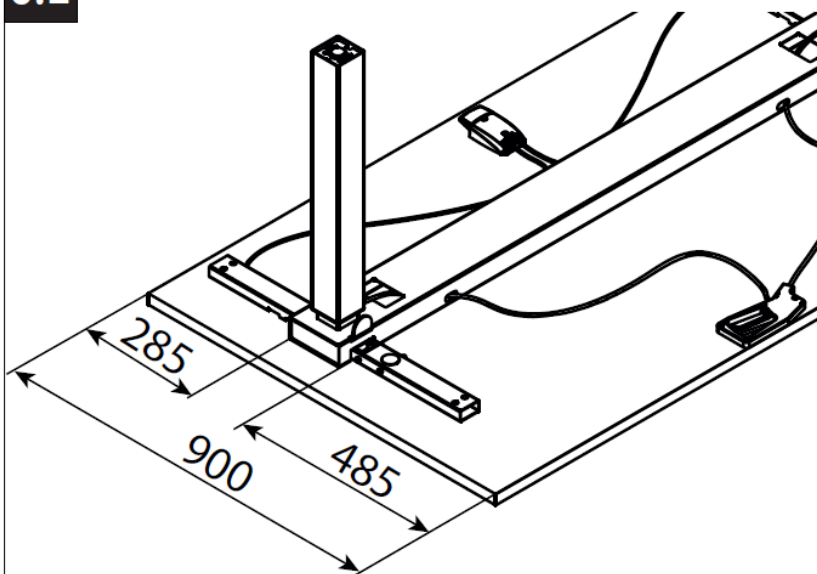

7

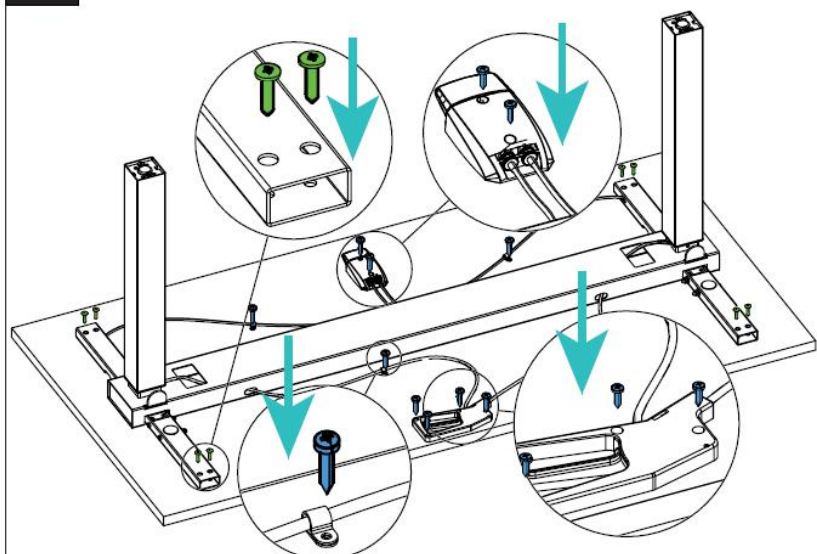

ø5 x 25



8x

ø4 x 16



10x



8.1

Variante / Variant 1

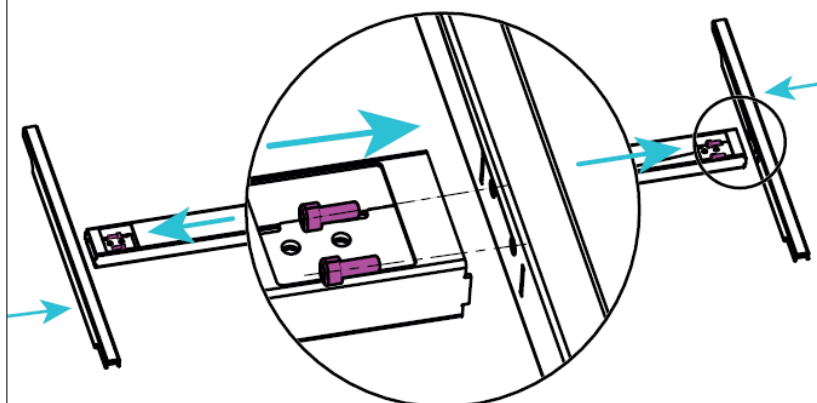

M8 x 20



4x

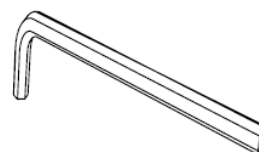

max. 12Nm

8.2

Variante / Variant 2

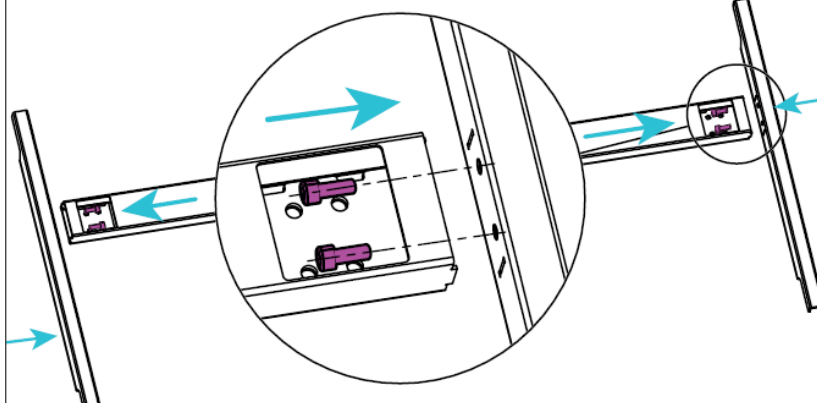

M8 x 20



4x

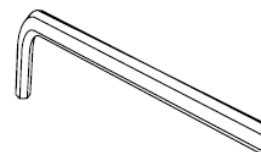

max. 12Nm

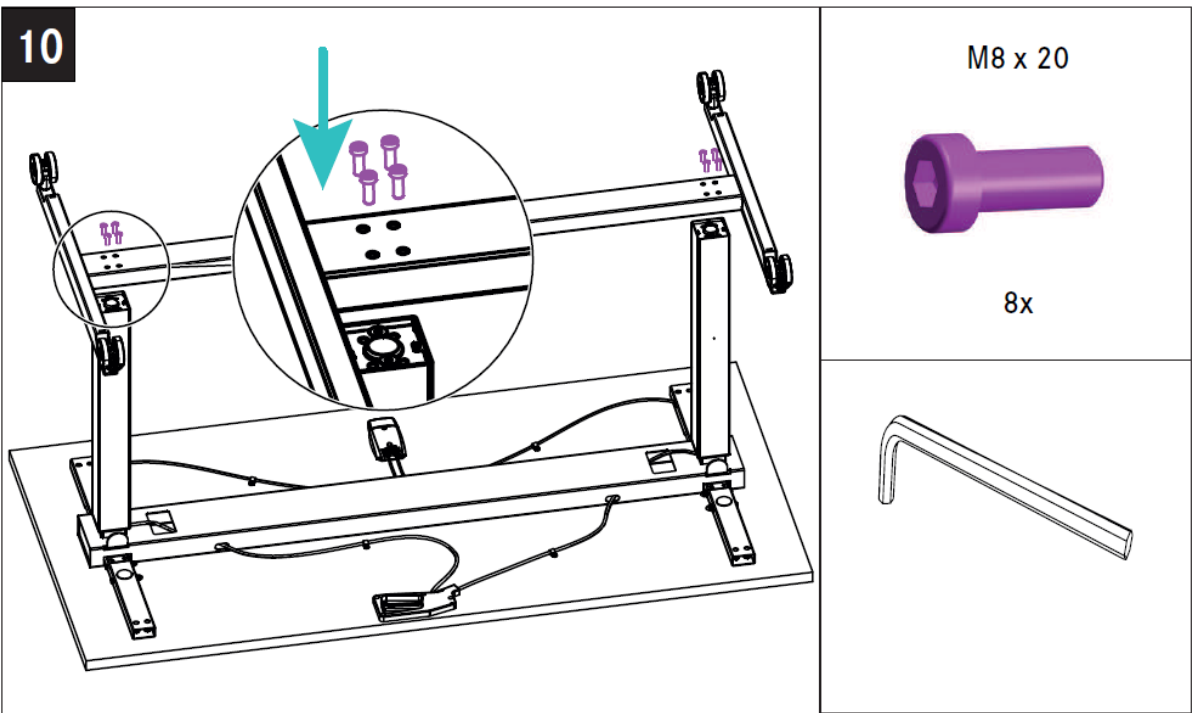
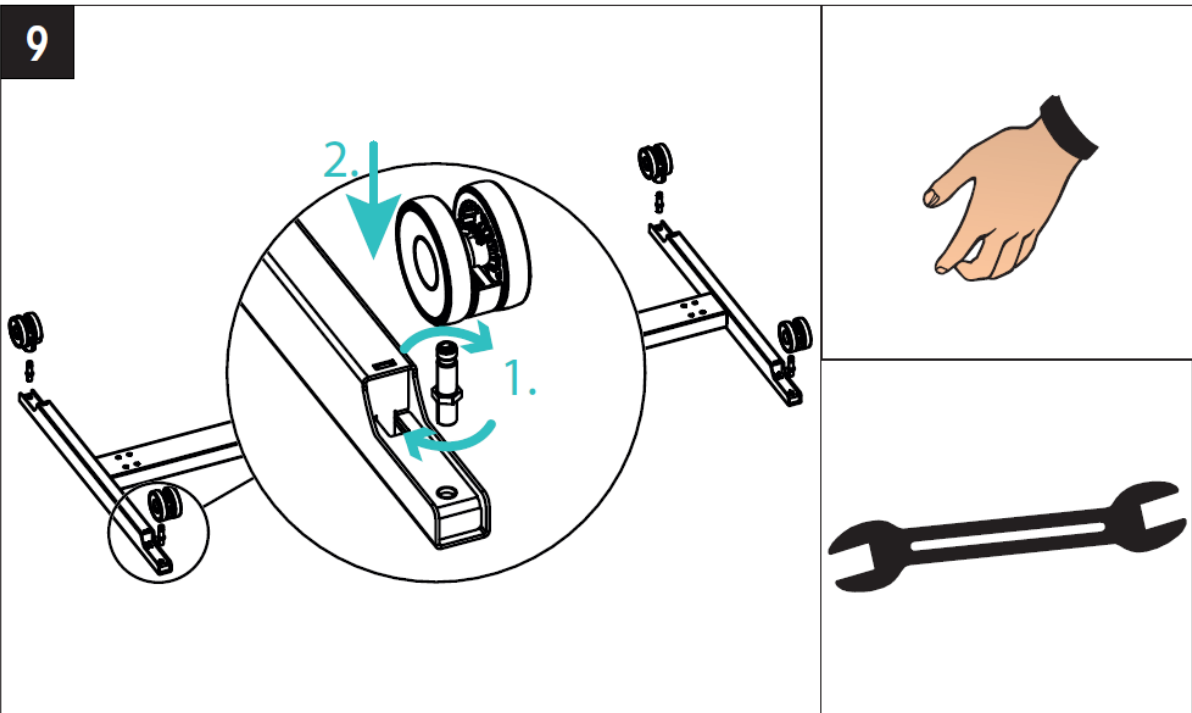



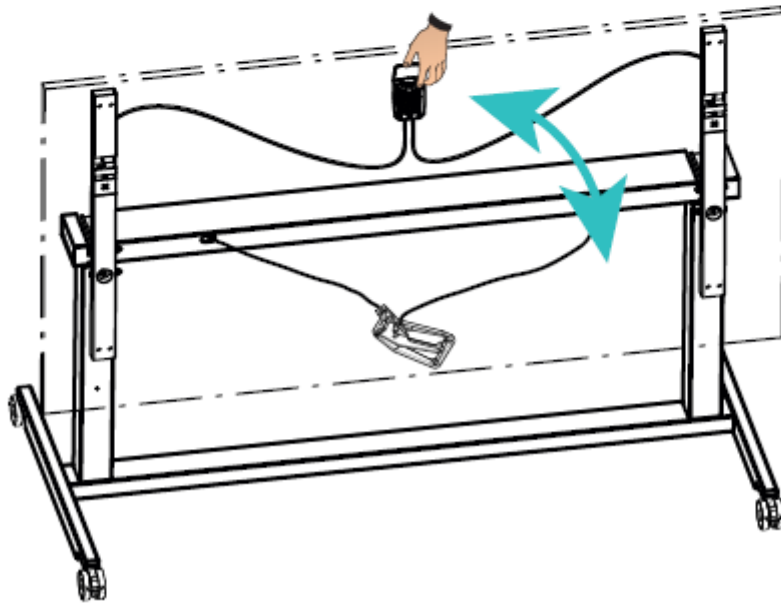
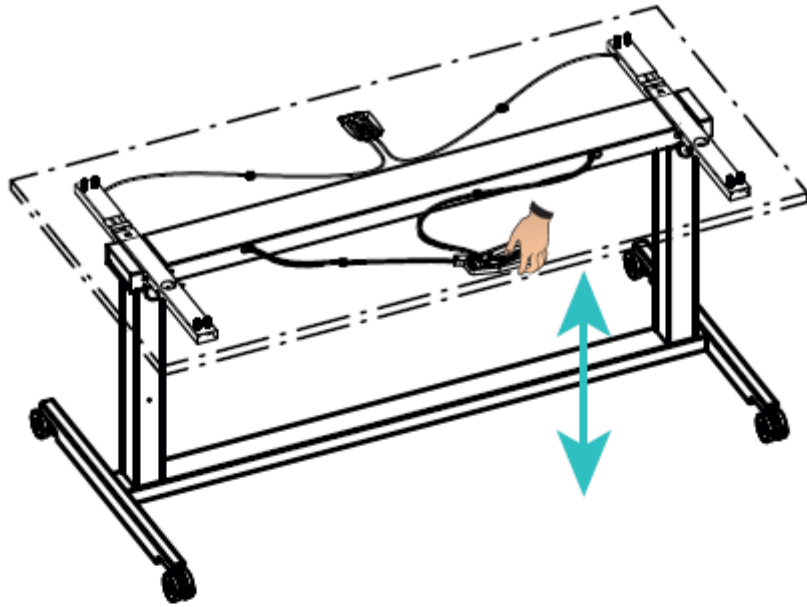

**BOX 15**

- INTERIOR UPSCALING -

### *Cleaning recommendations for powder-coated surfaces*

*For optimal care and cleaning of powder-coated surfaces the following recommendations should be followed:*

- Use only a soft cloth or industrial cotton wool. Refrain from rubbing hard.*
- Surface and cleaning agent temperature <25°C (do not steam clean surface).*
- Clean slight staining with clear water (cold or lukewarm), small amounts of neutral or alkaline detergent additives may be used, if necessary.*
- Stubborn staining, such as greasy or oily substances, may require the use of benzene hydrocarbons which are free of aromatic compounds (test previously in a hidden surface).*
- Do not apply detergent for extended periods of time. If necessary repeat cleaning process after 24 hours. Rinse well with cold, clean water immediately after cleaning.*
- Do not use scratching, abrasive agents.*
- Do not use acidic or strongly alkaline detergents and surfactants.*
- Do not use organic solvents which contain ester, ketone, alcohols, aromatic compounds, glycol ether, halogenated hydrocarbons or similar substances.*