

OPLA' TOP

ISTRUZIONI DI MONTAGGIO ASSEMBLY INSTRUCTIONS

MODELLI:
MODELS:

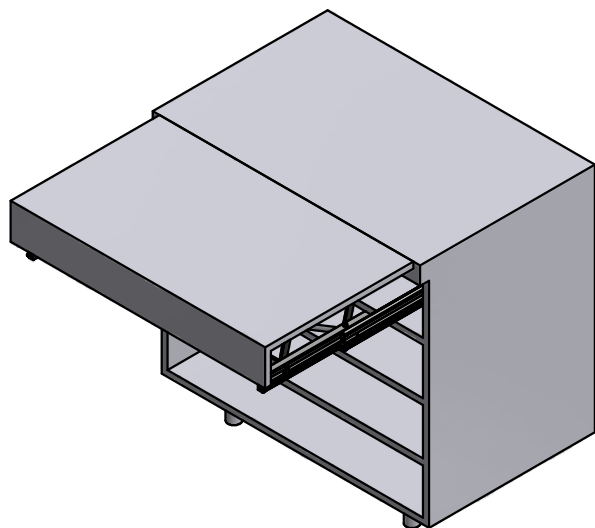





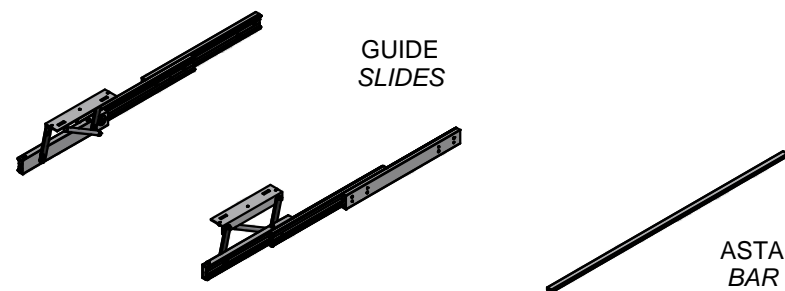



- 411/78.1750.22 Oplà top per modulo 450 mm, spalla 15-20 mm
Oplà top for 450 mm module, side 15-20 mm
- 411/78.1760.22 Oplà top per modulo 600 mm, spalla 15-20 mm
Oplà top for 600 mm module, side 15-20 mm
- 411/78.1770.22 Oplà top per modulo 900 mm, spalla 15-20 mm
Oplà top for 900 mm module, side 15-20 mm
- 411/78.1780.22 Oplà top per modulo 1200 mm, spalla 15-20 mm
Oplà top for 1200 mm module, side 15-20 mm



CONTENUTO DELLA CONFEZIONE INCLUDED IN THE PACKAGING



SACCHETTO ACCESSORI - ACCESSORIES

-  A. Chiave esa. n.5 - *n.5 Allen key*
-  B. Chiave esa. n.3 - *n.3 Allen key*
-  C. Molla - *Spring (x2)*
-  D. Ammortizzatore - *Dumper (x2)*
-  E. Bussola M6 12x8 mm - *Bush M6 12x8 mm (x12)*
-  F. Rondella Ø12x1.35 - *Washer Ø12x1.35 (x4)*
-  G. Vite TPS M5x12 - *M5x12 tapered screw (x2)*
-  H. Vite TCCE M6x12 - *Socked head cap screw M6x12 (x12)*
-  I. Vite TCBCE M5x10 ISO 7380 - *M5x10 ISO 7380 screw (x8)*
-  J. Distanziale per spalla - *Side spacer (x20)*

DIMENSIONI DI MASSIMA GENERAL DIMENSIONS

INGOMBRO IN ALTEZZA: 55
OVERALL HEIGHT



MODELLO - MODEL	MODULO - MODULE	L1 (mm)	L2 (mm)	L3 (mm)	L4 (mm)
411/78.1750.22	450	410-420	305.5-310.5	231-241	295.5
411/78.1760.22	600	560-570	455.5-465.5	381-391	445.5
411/78.1770.22	900	860-870	755.5-765.5	681-691	745.5
411/78.1780.22	1200	1160-1170	1055.5-1065.5	981-991	1045.5

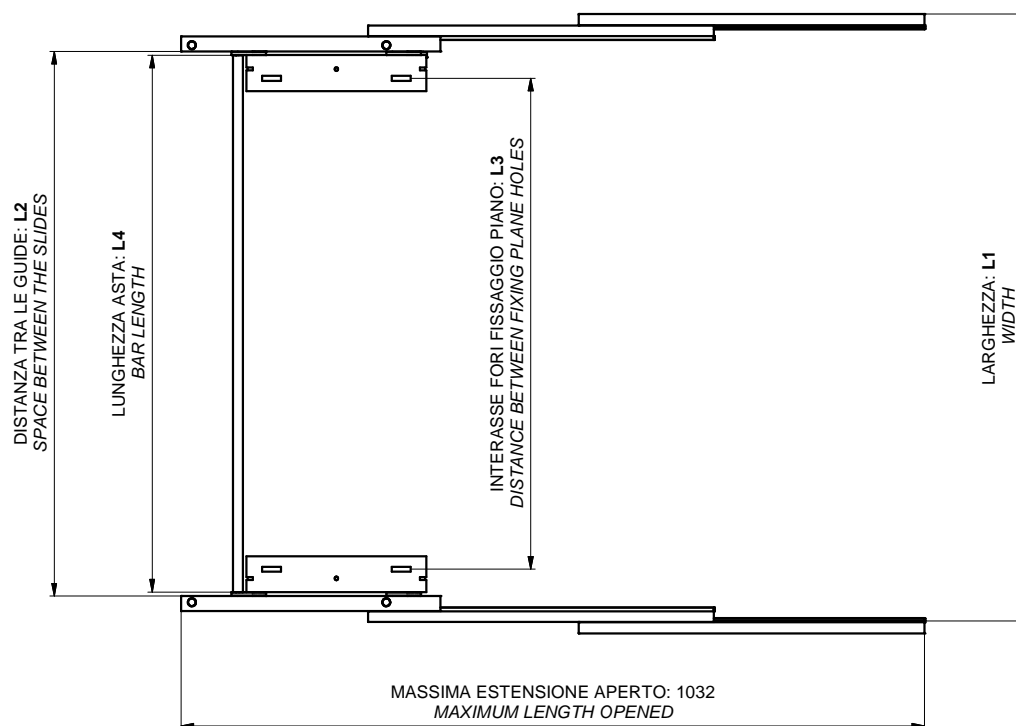

DIMENSIONI GENERALI MOBILE GENERAL CABINET DIMENSIONS

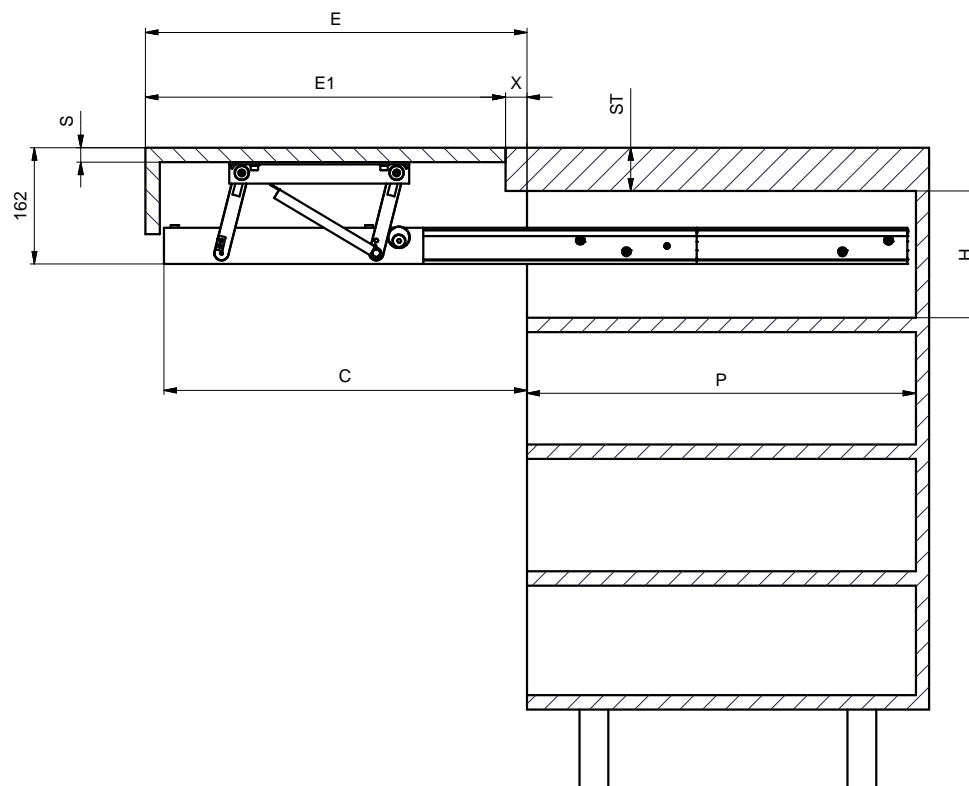
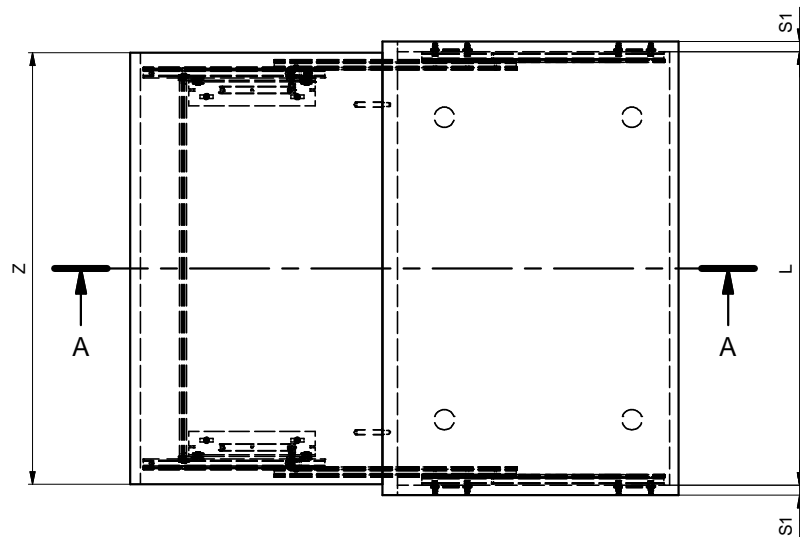

DIMENSIONE - DIMENSION	SIMBOLO - SYMBOL	-
LUCE VERTICALE - VERTICAL FREE SPACE	H	MIN: 145 mm - (ST-S)
PROFONDITA' INTERNA - INTERNAL FREE SPACE	P	MIN: 540 mm
LARGHEZZA INTERNA MODULO - CABINET INTERNAL WIDTH	L	MIN: 410 mm MAX: 1170 mm
SPESSORE PIANO - PLANE THICKNESS	S	20-60 mm
SPESSORE SPALLE - SIDE THICKNESS	S1	15-20 mm
SPESSORE TOP - TOP THICKNESS	ST	20-60 mm
LARGHEZZA PIANI - PLANE WIDTH	Z	L - 5 mm
SPORGENZA - PROTRUSION	X	-
APERTURA PIANI - OPENING PLANE	E	530 mm
LUNGHEZZA PIANO - LENGTH PLANE	E1	E-X
APERTURA MECCANISMO - OPENING MECHANISM	C	505 mm

POSIZIONE FORI FISSAGGIO MECCANISMO

HOLES FOR MECHANISM POSITION

A: Posizione fori diam. 8x13 per bussole M6

Position of diam. 8x13 holes for M6 bushes

B: Posizione scarichi da Ø10x5 per testa viti fissaggio distanziali

Position of Ø10x5 holes for the heads of screws fixing the spacers

Per spalle di spessore <20 mm usare i distanziali in ferro a corredo fissandoli sulle guide esterne.

For cabinet sides <20 mm use included steel spacers fixing them on the external slides

Spalla da 20 mm - nessun distanziale

Spalla da 19 mm - 1 distanziale

Spalla da 18 mm - 2 distanziale

Spalla da 17 mm - 3 distanziale

Spalla da 16 mm - 4 distanziale

Spalla da 15 mm - 5 distanziale

Side thickness 20 mm - no spacer

Side thickness 19 mm - 1 spacer

Side thickness 18 mm - 2 spacers

Side thickness 17 mm - 3 spacers

Side thickness 16 mm - 4 spacers

Side thickness 15 mm - 5 spacers

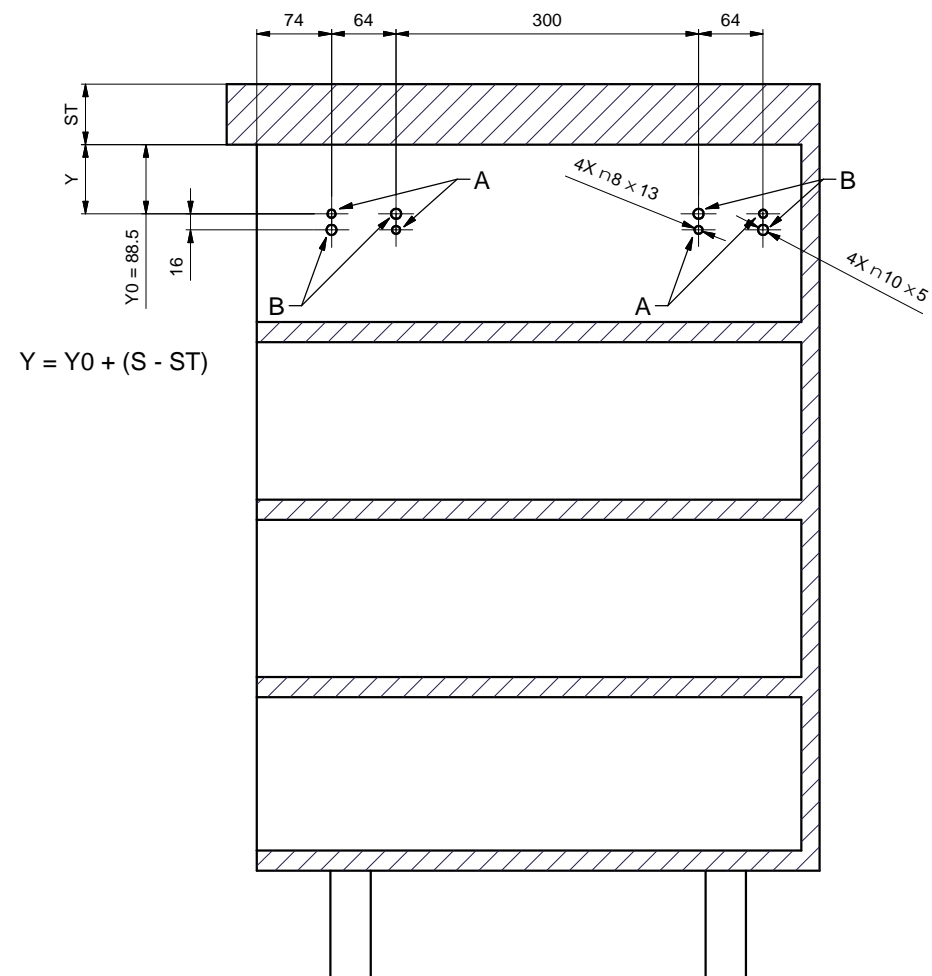
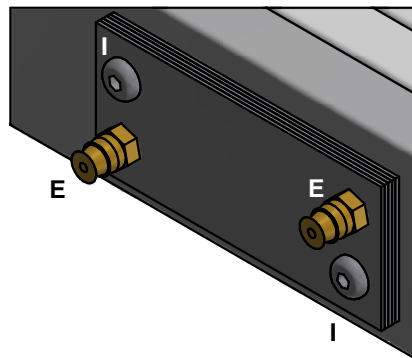

SACCHETTO ACCESSORI - ACCESSORIES



B. Chiave esa. n.3 - n.3 Allen key



J. Distanziale per spalla - Side spacer (x 20)



E. Bussola in ottone M6 12x8 mm - M6 12x8 mm brass bush (x 8)



I. Vite TCBCE M5x10 ISO 7380 - M5x10 ISO 7380 screw (x 8)

DIMENSIONE PIANO PLANE SIZE

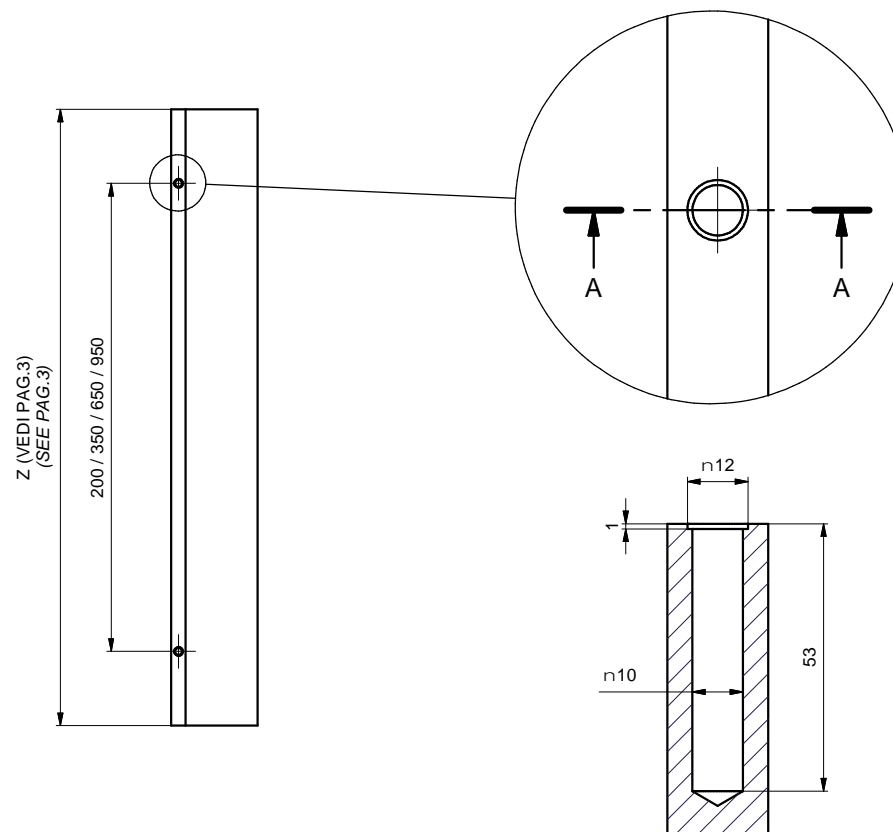
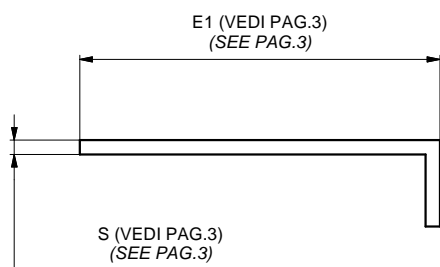
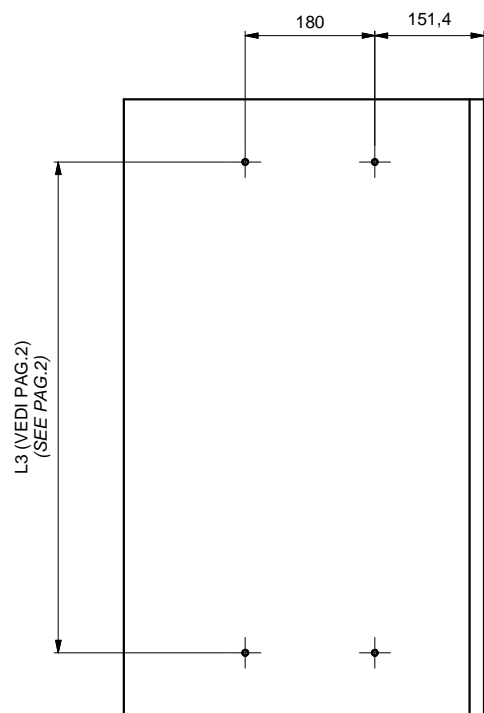

SACCHETTO ACCESSORI - ACCESSORIES



D. Ammortizzatore - *Dumper* (x2)





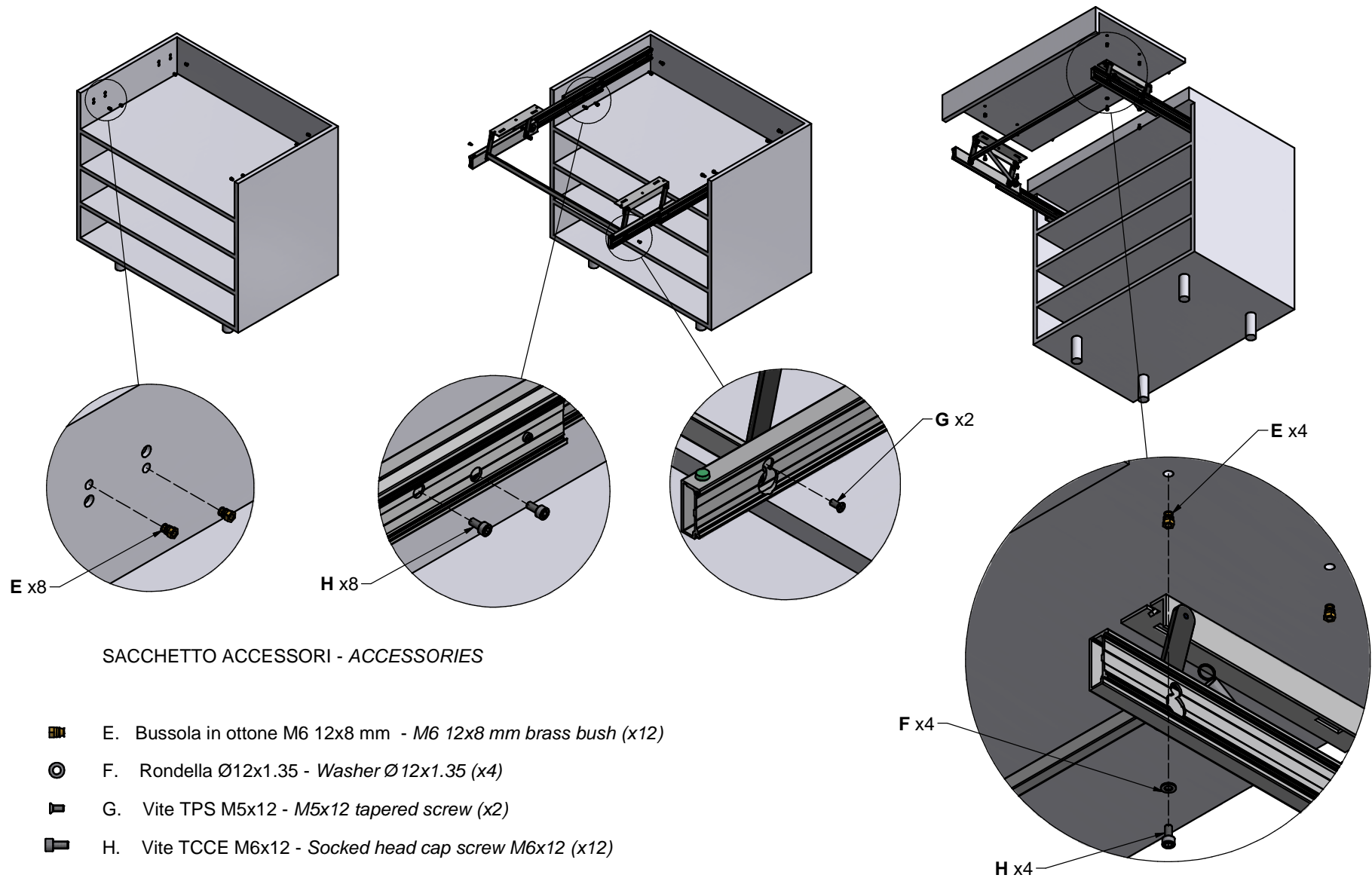

E. Bussola M6 12x8 mm - *Bush M6 12x8 mm* (x4)

MONTAGGIO DEL MECCANISMO SUL MOBILE MOUNTING OF THE MECHANISM ON THE CABINET



SACCHETTO ACCESSORI - ACCESSORIES

-  E. Bussola in ottone M6 12x8 mm - M6 12x8 mm brass bush (x12)
-  F. Rondella Ø12x1.35 - Washer Ø12x1.35 (x4)
-  G. Vite TPS M5x12 - M5x12 tapered screw (x2)
-  H. Vite TCCE M6x12 - Socked head cap screw M6x12 (x12)

MONTAGGIO DEL MECCANISMO SUL MOBILE

MOUNTING OF THE MECHANISM ON THE CABINET

SACCHETTO ACCESSORI - ACCESSORIES



C. Molla - Spring (x2)

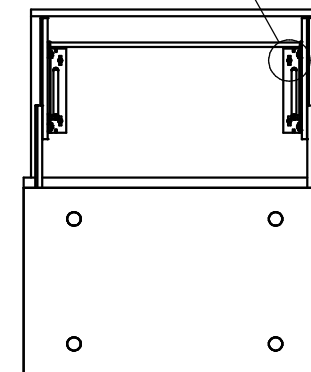
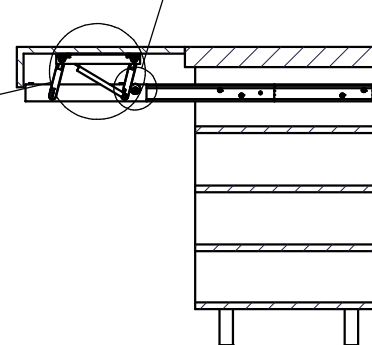
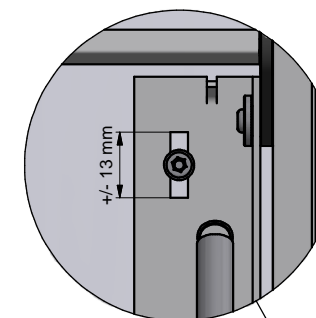
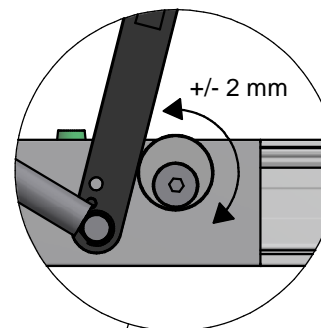
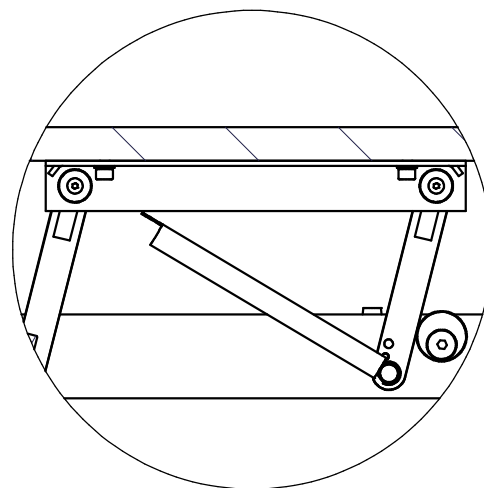
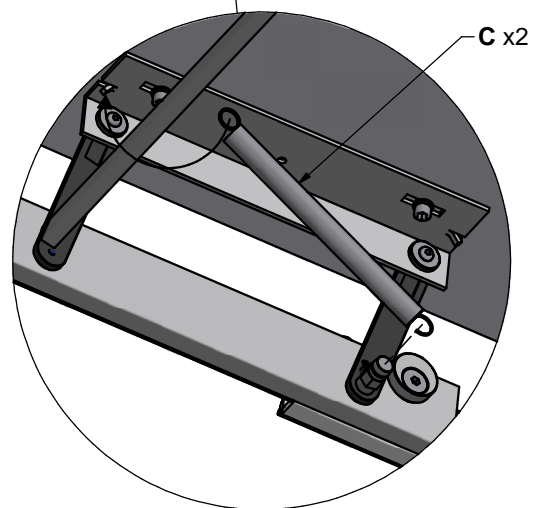
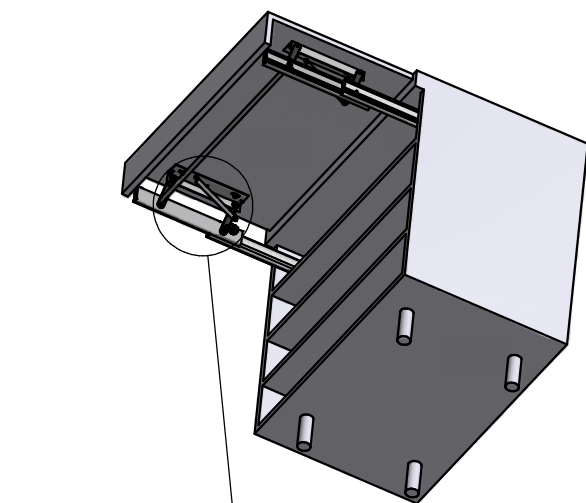

TROVARE LA POSIZIONE E FISSARE IL PIANO
CON DUE VITI TRUCIOLARI (NON FORNITE)
FIND POSITION AND FIX THE PLANE WITH
TWO SCREWS CHIPBOARD (NOT SUPPLIED)